

Mr.Driveshaft

MRD-6

NOTE — Vehicle MUST Be At Ride Height
(Wheels on ground or Diff. Loaded)

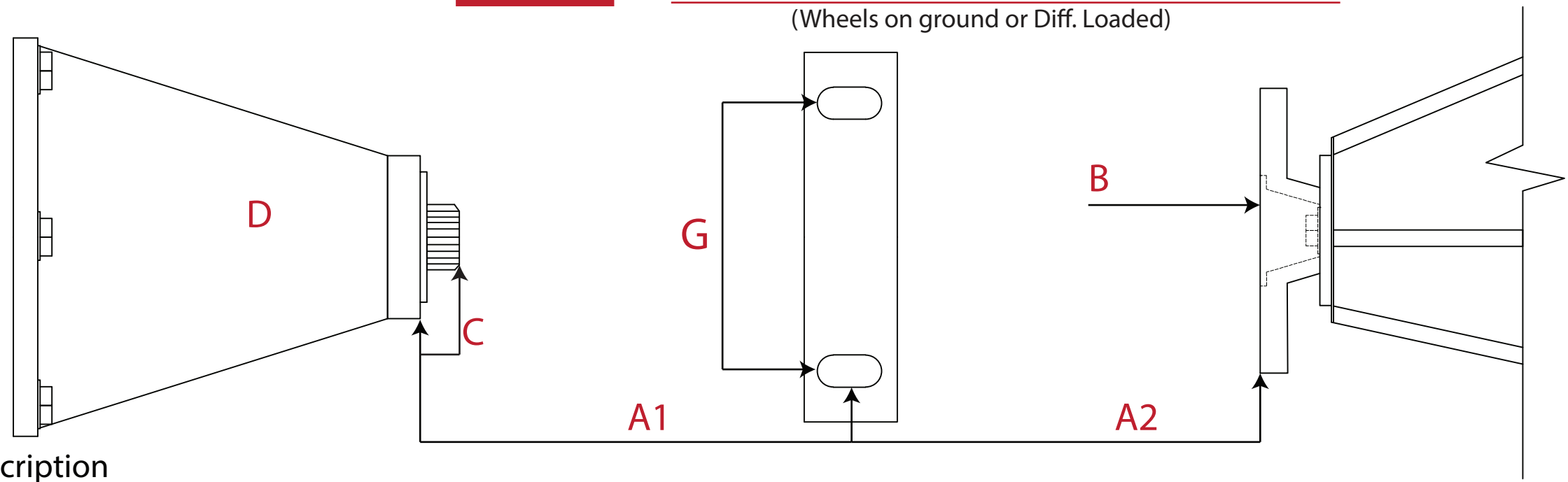

Vehicle Description _____

A1 Seal To C of hanger Length _____

A2 C of hanger to Flange _____

B Pilot Raised Recessed

C Spline Out Past Seal Y N
How Long _____

D Trans Type _____
Output Spline Count _____

U-Joint Series Desired _____

E Pilot Hole Diameter _____

F Bolt Circle Diameter _____

G Hanger width _____

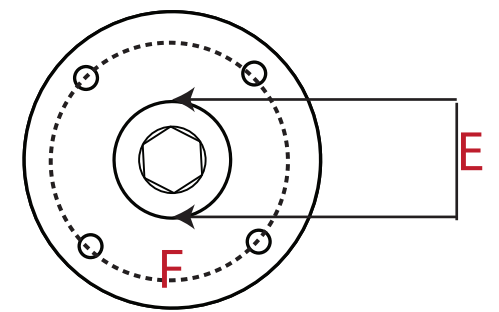

Name _____

Phone # _____

Please Use Vehicle For All Measurements (Not Your Old Shaft)

