

Mr.Driveshaft

MRD-4.5

NOTE — Vehicle MUST Be At Ride Height
(Wheels on ground or Diff. Loaded)

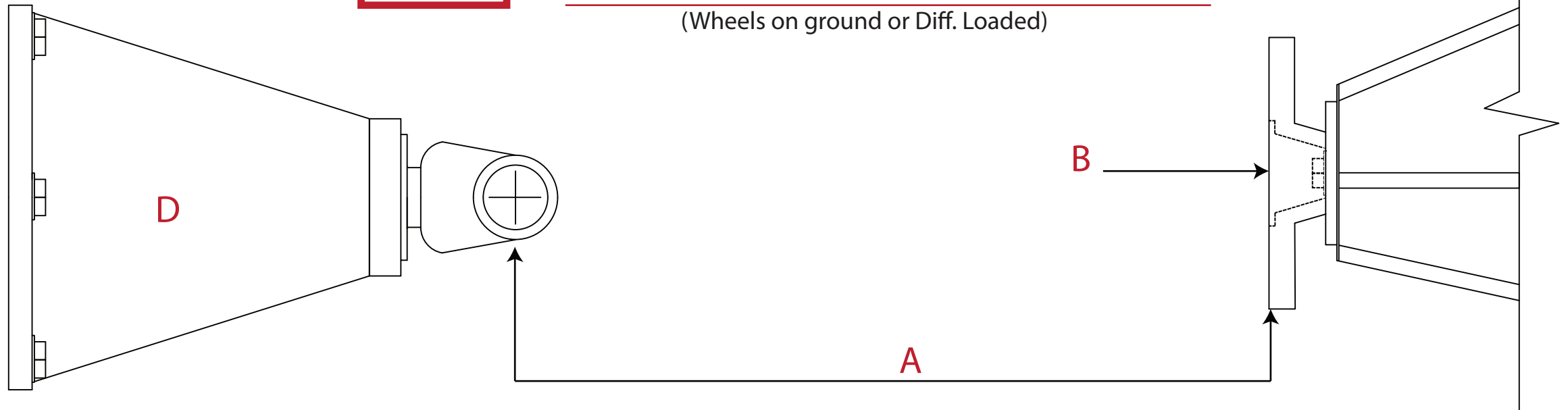

Vehicle Description _____

A Center To Flange Length _____

B Pinion Raised Recessed

D Trans Type _____
Output Spline Count _____

Any Additional Notes On Application _____

Name _____

Phone # _____

Please Use Vehicle For All Measurements (Not Your Old Shaft)

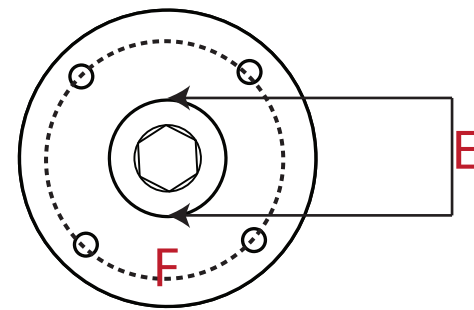

U-Joint Series Desired _____

E Pinion Hole Diameter _____

F Bolt Circle Diameter _____

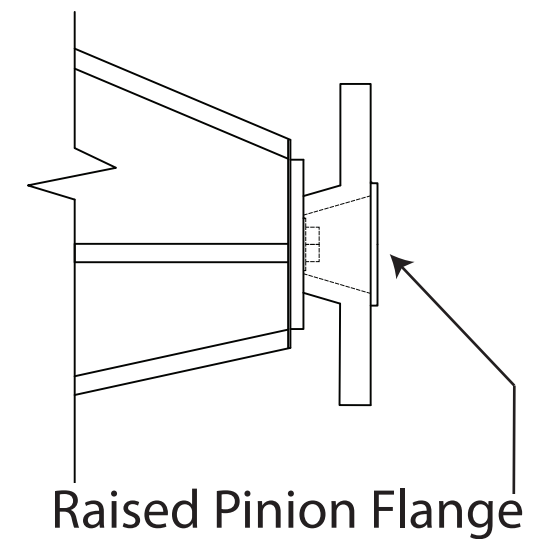
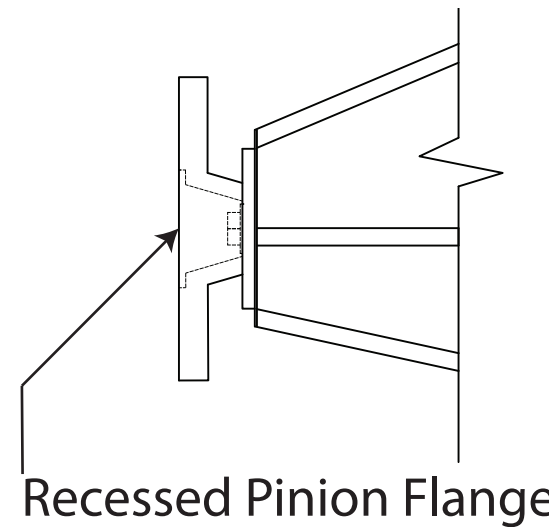

Phone: 732-938-4118

Fax: 732-938-3545

www.mrdriveshaft.com

5134A WEST HURLEY POND ROAD
FARMINGDALE, NJ 07727